

Kymera 43



IBRIDO, TRA MITO E LEGGENDA

Il primo battello ibrido della flotta Sea Water, un concentrato di tecnologia e stile che non perde le caratteristiche di stabilità, maneggevolezza e sicurezza tipiche delle sorelle dotate di gonfiabile.

Questa imbarcazione delinea la strada intrapresa dal brand verso il mercato dell'ibrido, un battello di 13m, dotato di grandi spazi per la vivibilità di bordo sia in coperta che sottocoperta.

La coperta di questo battello è ampia e accogliente, come da tradizione per le imbarcazioni prodotte dal cantiere Sea Water, dove il comfort è una delle priorità.

Sotto la consolle si trovano il comodo bagno con wc, doccia e mobile con lavabo e la cabina, il cui accesso avviene tramite una porta laterale lungo il camminamento che porta da prua a poppa.

Rimane sempre valida la possibilità di customizzare il mezzo con innumerevoli soluzioni che lasciano il più ampio spazio di scelta all'armatore, rispecchiando il vero significato del tailor made.





HYBRID, BETWEEN MYTH AND LEGEND

The first hybrid boat in the Sea Water fleet, a concentrate of technology and style that does not lose the stability, handling and safety features typical of its inflatable sisters.

This boat delineates the path taken by the brand towards the hybrid market, a 13m boat with large spaces for on-board living both on deck and below deck.

The deck of this boat is large and welcoming, as is the tradition for boats produced by the Sea Water yard, where comfort is a priority.

Under the console is the comfortable bathroom with toilet, shower and cabinet with washbasin and the cabin, which is accessed through a side door along the walkway leading from bow to stern.

The possibility of customising the vessel with countless solutions that leave the owner as much room for choice as possible, reflecting the true meaning of tailor-made, always remains valid.

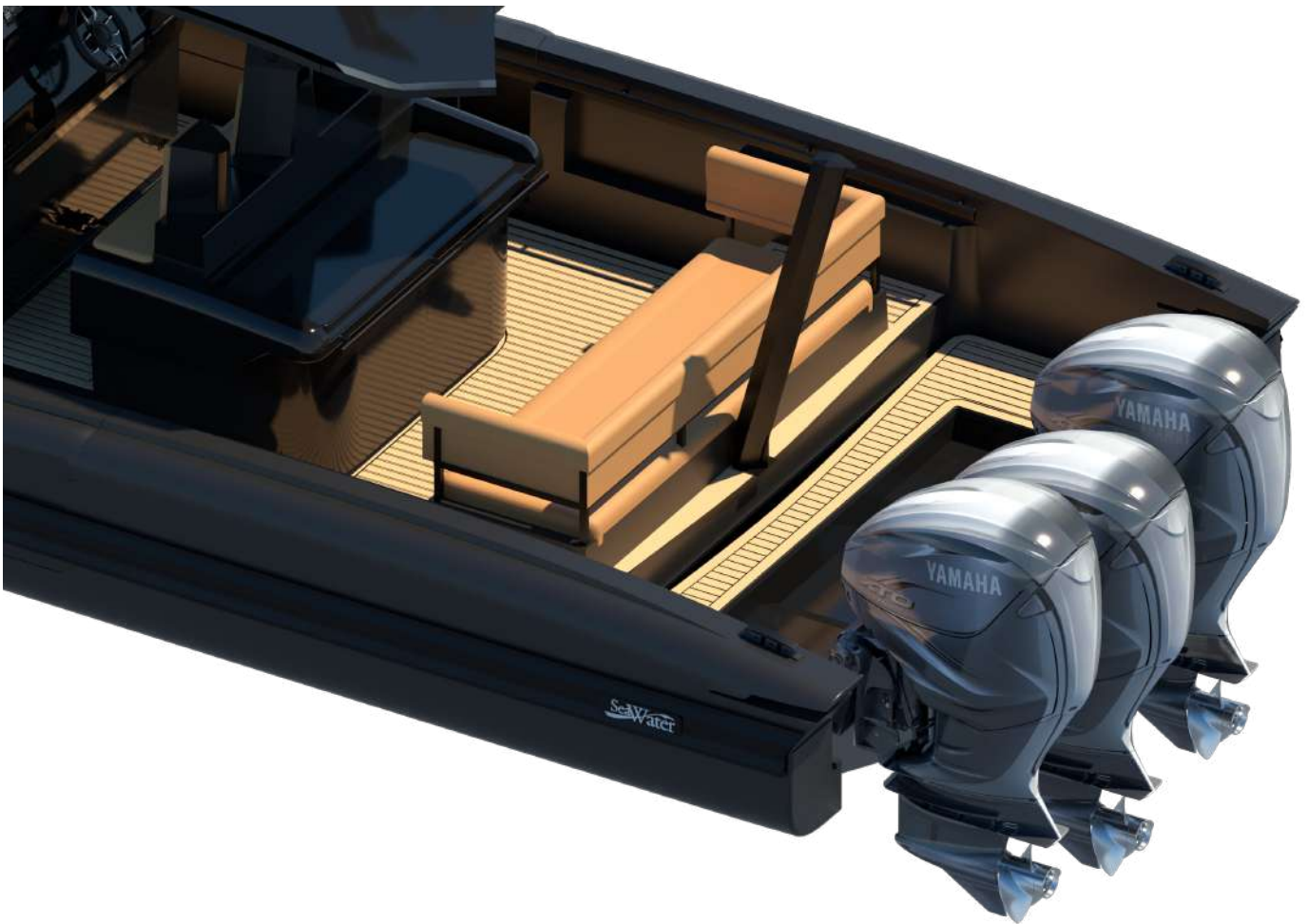



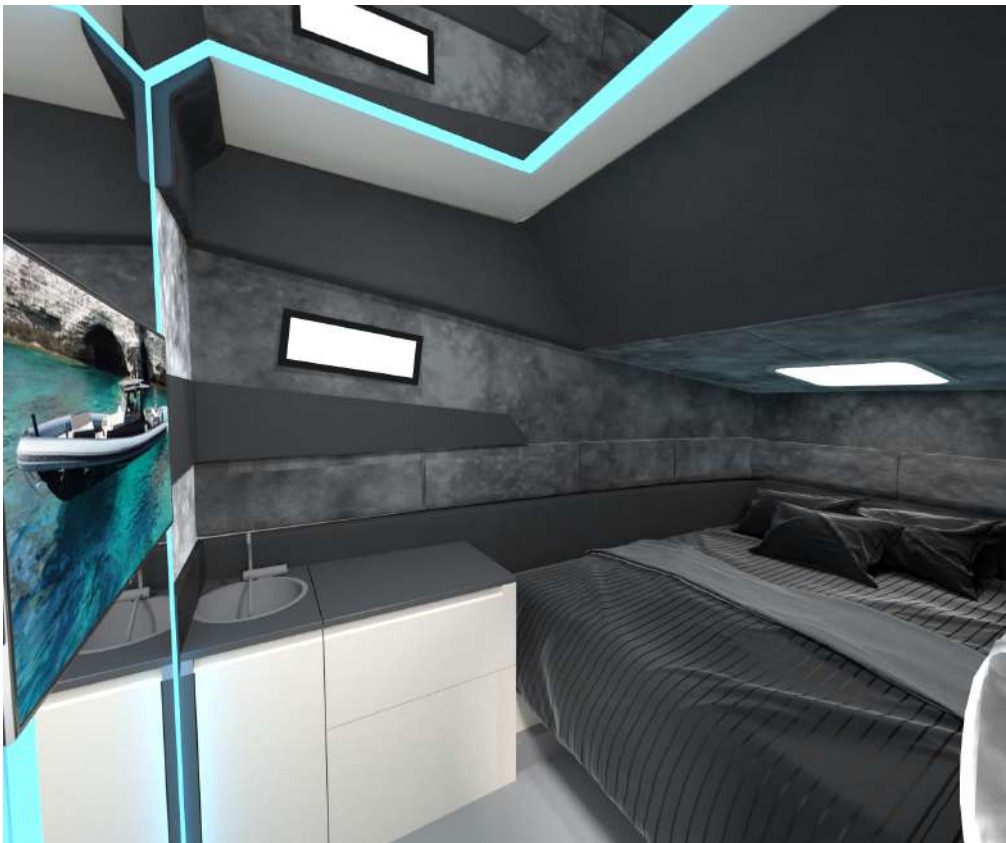

**Le immagini riprodotte nella presente brochure sono puramente indicative e riportate a scopo illustrativo. Pertanto potrebbero differire dal reale aspetto dell'imbarcazione.*

**The images reproduced in this brochure are purely indicative and reported for illustrative purposes. Therefore they could differ from the real aspect of the boat.*





KYMERA 43

General characteristics

Motorization	n.	hp	kW
Yamaha XTO	3	425	951
Yamaha XTO	2	425	634
Speed	Cruising		Max
Speed at 1/3 displacement loaded (3 engines)		35kts	49kts
Speed at 1/3 displacement loaded (2 engines)		35kts	42kts
Main sizes	m		ft
Loa = overall length (std. ISO8666)		13,76	45,2
Lh = hull length (std. ISO8666)		13,06	42,1
Lg = waterline length (boat fully laden)		11,35	37,3
Maximum beam		4,13	13,7
Depth under propellers (boat fully laden)		1,1	3,7
H = overall height from keel to hard top		3,2	10,6
Ht = minimum transport height from keel		3,2	10,6
P = pulpit		0	0
Capacity	lt		USgals
Standard fuel tank		1480	391
Water tank		220	58
Displacement	ton		lb
Unladen		5,8	12871
Laden		9,8	21217
Guests			
Max. number of guests			25
Navigation category CE 94/25			A
Certification modules	B		UDICER
Hull type			Monohedron
Deadrise			19° and spray rails

Performance specifications:

Performances are estimated at standard version displacement of the yacht (7,1 ton/ 15652,82 lb), at 1/3 of load, clean hull, 25° C air temperature, good weather conditions and special props stotted for these conditions. If overloading the yacht by 0,5 ton/1102,31 lb, top speed decreases of 1 kts.

Building materials:

Building process: Infusion - Materials: reinforced glass and carbon fibre; core PVC closed cell, vinylester resin infusion - Lamination process: single skin laminate (bottom) and sandwich (sides and deck)



KYMERAYACHT S.R.L.

SEDE LEGALE: via Giuseppe Mercalli 24A, 09129, Cagliari (Ca)
SEDE OPERATIVA: Z.I. Macchiarèdu, Strada Tre SNC, 09032, Assemini (Ca)
P. IVA: 03801300926 - *TELEFONO:* +39.392.591.4869
PEC: kymerayacht@pec.it *EMAIL:* kymerayacht@gmail.com
www.seawater.it